

ABSOLUTE MAXIMUM RATINGS

Item	Symbol	Min.	Max.	Unit
Supply Voltage(Logic)	Vdd - Vss	-0.3	4.0	V
Supply Voltage(LCD)	Vlcd	-0.3	13.2	V
Input Voltage	Vi	-0.4	Vdd + 0.3	V
Operating Temp.	Topr	-10	60	°C
Storage Temp.	Tstg	-20	70	°C

MECHANICAL DATA

Item	Max.	Unit
Module Size (W X H X T)	80.6 X 69.3 X 8.0	mm
Viewing Area(W X H)	72.5 X 39.0	mm
Dot Pitch(W X H)	0.52 X 0.52	mm
Dot Size(W X H)	0.48 X 0.48	mm
View Angle	6 O'Clock	

ELECTRICAL CHARACTERISTICS (Vdd=3.0V±0.3V)

Item	Symbol	Test Condition	Min.	Typ.	Max.	Unit
Input High Voltage	Vih	--	0.8Vdd	--	--	V
Input Low Voltage	Vil	--	--	--	0.2Vdd	V
Output High Voltage	Voh	--	0.8Vdd	--	--	V
Output Low Voltage	Vol	--	--	--	0.2Vdd	V
Current consumption	Idd	Vdd=3.0V	--	239	--	μA
LCD Driving Voltage	V0	Ta=25 °C	--	9.0	--	V

PIN CONNECTIONS

Pin	Symbol	Function
1	NC	BLANK
2	CS0	Chip select pin
3	RST	Reset signal input
4	CD	"L": Control data; "H": Display data
5	WR	Write Select Signal
6	RD	Read Enable Signal
7~14	D0~D7	Display Data Signal
15	BM0	MCU interface selection input
16	BM1	Parallel/Serial interface selection input
17	ID	ID may be used for production identification.
18	VDD	Power Supply for Logic(+3.3V)
19	VSS	Ground
20	TST4	Test control, Connect to GND during normal operation
21	VB1+	LCD Bias Voltages
22	VB1-	
23	VB0-	
24	VB0+	
25	VLCD	Main LCD Power Supply
26	NC	BLANK

BLOCK DIAGRAM

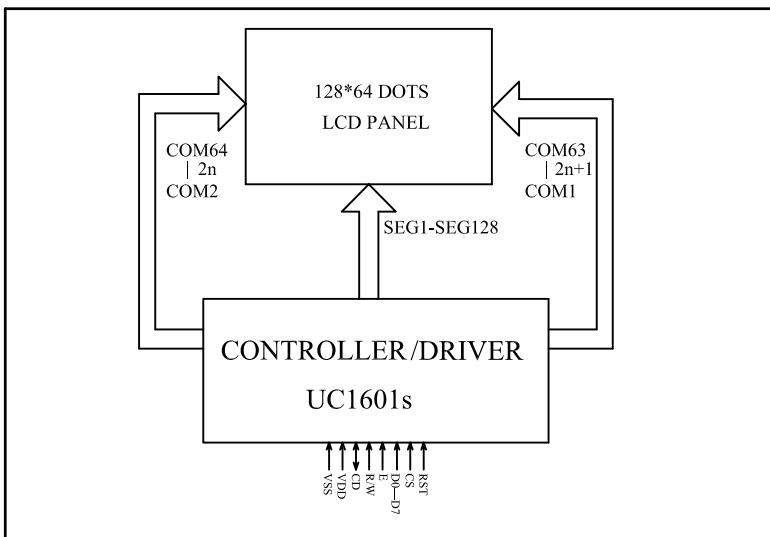

LCD Type

LCD Color	Backlight
STN/Yellow-Green	Yellow-Green /3.2V,40mA